

SCHMEISER[®]
VINEYARD DRILL
2nd GENERATION – SERIES '98

ASSEMBLY & PARTS
MANUAL



T.G. SCHMEISER CO., INC.
P.O. BOX 1047 FRESNO, CA 93714
(559) 268 - 8128 FAX (559) 268 – 3279
www.tgschmeiser.com

VERSION 3.1a
JULY 2013

INTRODUCTION

Your Schmeiser Vineyard Drill is designed to give you many years of dependable service. This manual has been prepared to instruct you in the safe and efficient operation of this machine. Read and study it thoroughly. Follow all instructions carefully.

Should your Vineyard Drill require replacement parts, go to your Schmeiser dealer. Always order genuine Schmeiser replacement parts.

It is important that you complete and send in your Warranty Card because it is not valid unless it is on file at Schmeiser. If you need information not contained in this manual, contact your Schmeiser dealer.

Space has been provided below for you to record the model number and serial number of your drill. Be sure to bring this information with you to your dealer when ordering parts or attachments for your drill.

Thank you for buying a Schmeiser Vineyard Drill/Seeder.

SERIAL NUMBER _____

MODEL NUMBER _____

DATE PURCHASED _____

DEALER NAME _____

NOTE: Please refer to page 19 for your serial number plate location.

TABLE OF CONTENTS

Introduction.....	2
Table of Contents.....	3
Safety Rules.....	4
Vineyard Drill Models.....	5
Seed Rate Calibration.....	6
Seed Rate Chart.....	7
Seed Cup.....	8
Planting Depth Adjustments.....	9
Press Wheel Adjustment.....	10
Sprocket and Chain Assemblies.....	11
Vineyard Drill Box Assembly.....	12
Feeder Cup and Drive Components.....	14
Feeder Cup Assembly.....	16
Main Frame, Wheel Leg, and Walk Board Assemblies.....	18
Jack Shaft, Sprocket, Idler and Bearing Assemblies.....	20
Double Disk Opener Assembly.....	22
Double Disk Opener Press Wheel Assembly.....	24
No-Till Vineyard Drill Parts.....	26
No-Till Vineyard Drill Sprocket and Chain Assemblies	29
Warranty.....	30
Maintenance and Repair Record.....	31
Notes.....	32

SAFETY RULES

The safe operation of any machinery is a big concern to farmers and manufacturers. We have designed our Vineyard Drill with many built-in safety features. However, no one should operate this machine before carefully reading this Owner's Manual.

1. Never permit anyone to ride on or walk beside the Vineyard Drill when moving.
2. Never permit anyone to ride on tractor when Vineyard Drill is being moved.
3. Never allow anyone to be near the Vineyard Drill when performing operating functions with Drill or tractor.
4. Never load Vineyard Drill without being hooked-up to tractor.
5. Extra care should be taken when transporting with seed in the box.
6. Never back Vineyard Drill up when openers are in ground.
7. Reduce speed of tractor when transporting over uneven or rough terrain. Avoid all chuck holes and washboard areas in road.
8. Reduce speed of tractor when transporting over hills or steep slopes.
9. Always set Vineyard Drill in field position before lubrication.
10. Do **NOT** lubricate, adjust or repair the Vineyard Drill while it is in operation.
11. When in transport, use accessory lights and devices for adequate warning to operators of other vehicles, and use safety chains. Comply with all Federal, State and local laws when traveling on public roads.
12. Use "Slow Moving Vehicle" emblem for warning vehicles approaching from rear.
13. Do **NOT** permit smoking, sparks, or an open flame where combustible lubricants, or liquids are being used.
14. When using treated grain, avoid direct contact with the seed.
15. When using compressed air to clean Vineyard Drill, wear safety glasses.
16. When transporting, remember the Vineyard Drill may be wider than your tractor and extreme care must be taken to allow for safe clearance.

SCHMEISER[®] VINEYARD DRILL MODELS



VD-36PW – 3 FT. VINEYARD DRILL STANDARD

VD-48PW – 4 FT. VINEYARD DRILL STANDARD

VD-60PW – 5 FT. VINEYARD DRILL STANDARD

VD-72PW – 6 FT. VINEYARD DRILL STANDARD



VDNT-36PW – 3 FT. VINEYARD DRILL NO-TILL

VDNT-48PW – 4 FT. VINEYARD DRILL NO-TILL

VDNT-60PW – 5 FT. VINEYARD DRILL NO-TILL

VDNT-72PW – 6 FT. VINEYARD DRILL NO-TILL

SCHMEISER VINEYARD DRILL SEED RATE CALIBRATION

Note: Seeding rates will vary greatly with variations in sizes of seeds. Although the seeding rates listed in this manual are based on an average seed size, we recommend that you test and adjust your Vineyard Drill using the procedures listed below.

- 1) There are many factors, which will affect seeding rates: Seed treatment, weight of seed, size of seed, surface condition of seed, tire configuration and pressure, and tire slippage. Minor adjustments will probably be needed to compensate for the above factors.
- 2) The rates listed in the seed charts are based in the gauge wheel drive having 20.5 x 8.0 x 10 tire with the recommended tire inflation.
- 3) The large difference in seed size and treatment can cause a wide variation in actual seeding rates. The rate charts are based on average size seed. This may differ from the seed you are using. Use the seed rate charts as a guide only. Set the pounds per planted acre desired at the indicator number and complete the following procedure to calibrate the rate for specific seed.
 - a. Place several pounds of seed over three feeder cups at the outboard end of the Vineyard Drill.
 - b. Pull the seed tubes out of these three drops.
 - c. Raise the drive wheel off the ground.
 - d. Rotate the tire to see that the drive system is working properly and that the feed cups are free from foreign matter.
 - e. Place a container under the three seed tubes to gather seed as it is metered.
 - f. On 3 ft. wide models rotate the tire 54 times to obtain 1,000 square feet. On 4 ft. wide models rotate the tire 48 times to obtain 1,000 square feet. On 5 ft. wide models rotate the tire 38 times to obtain 1,000 square feet. On 6 ft. models rotate the tire 32 times to obtain 1,000 square feet. Be sure to check the three feeder cups to make sure each cup has plenty of seed coming into it.
 - g. Weigh the seed, which has been metered. Divide by three. This will give you the ounces/pounds metered by each feeder cup. Multiply by the number of cups on your Vineyard Drill to arrive at the total pounds per 1,000 square feet. Now multiply by 43.56 to arrive at the total pounds per planted acre. If this figure is different than desired, set your feed cup adjustment lever accordingly.
- 4) You may want to repeat the calibration procedure if the results of your calibration vary greatly from the suggested settings contained in this manual.

REMEMBER: Tire size and field conditions will also affect seeding rates. Be certain that your Vineyard Drill tires are 20.5 x 8.0 x 10 and that they have the proper inflation. When seeding, check the amount of seed you are using by noting area seeded, amount of seed added to box, and level of seed in seeder box. If you suspect that you are seeding more or less seed than desired, and you have accurately calibrated the Vineyard Drill to your seed, you may need to adjust the seeding rate slightly to compensate for your field conditions.

SEEDING RATES FOR SCHMEISER VINEYARD DRILL



Rates in Pounds per Planted Acre

August 1, 2001

Sprocket Combination:

13/33 x 12/33

Seed	Seed Rate Indicator Setting Number									
	10	20	30	40	50	60	70	80	90	100
	POUNDS PER ACRE									
Barley	12	23	42	56	69	91	106	118	132	147
Bio Max Cover Crop*	14	28	56	75	93	128	149	172	194	216
Clover - Perennial	17	35	57	77	96	119	139	152	171	190
Cover Crop Mix #1*	16	31	64	86	106	139	162	182	205	227
Cover Crop Mix #2*	22	44	69	92	115	145	169	182	195	209
Cover Crop Low Profile*	18	37	64	85	106	127	147	171	193	213
Cover Mate Mix*	7	14	21	27	34	39	46	52	57	64
Crimson/Berseem	18	36	53	72	89	114	132	150	168	186
Insectary Mix*	16	33	55	74	91	107	126	152	159	177
Pearl Millet	20	39	65	86	107	148	173	218	246	273
Rye Grass - Annual	8	14	29	39	48	63	74	85	95	106
Sorghum Sudan	14	28	54	73	90	125	152	178	200	222
Sudan Bravo Brand	15	30	52	69	86	109	128	145	164	181
Vetch - Common	18	38	73	96	120	145	169	182	205	228
Winter Forage #1*	10	21	39	52	65	83	96	116	130	145

CAUTION: THESE RATES ARE APPROXIMATE ONLY. PLEASE VERIFY OUTPUT PRIOR TO FIELD USE.

*** Germain's Seed**

2ND GENERATION – SERIES '98

THIS CHART APPLIES TO VINEYARD DRILLS MANUFACTURED AFTER JANUARY 2001

NOTE: INSURE THAT SQUARE SEED CUP SHAFT IS WELL LUBRICATED WHERE SHAFT GOES THROUGH CUP DRIVE BEARING (SEE **Page 15**)

SEED CUP

IMPORTANT: Be sure to adjust seed cup lever position prior to loading seed in hopper.

WARNING: Closing seed lever with seed in cup may damage or break lever.

It is important to select the correct lever position. The incorrect position may cause
a) seed damage and/or **b)** cup damage.

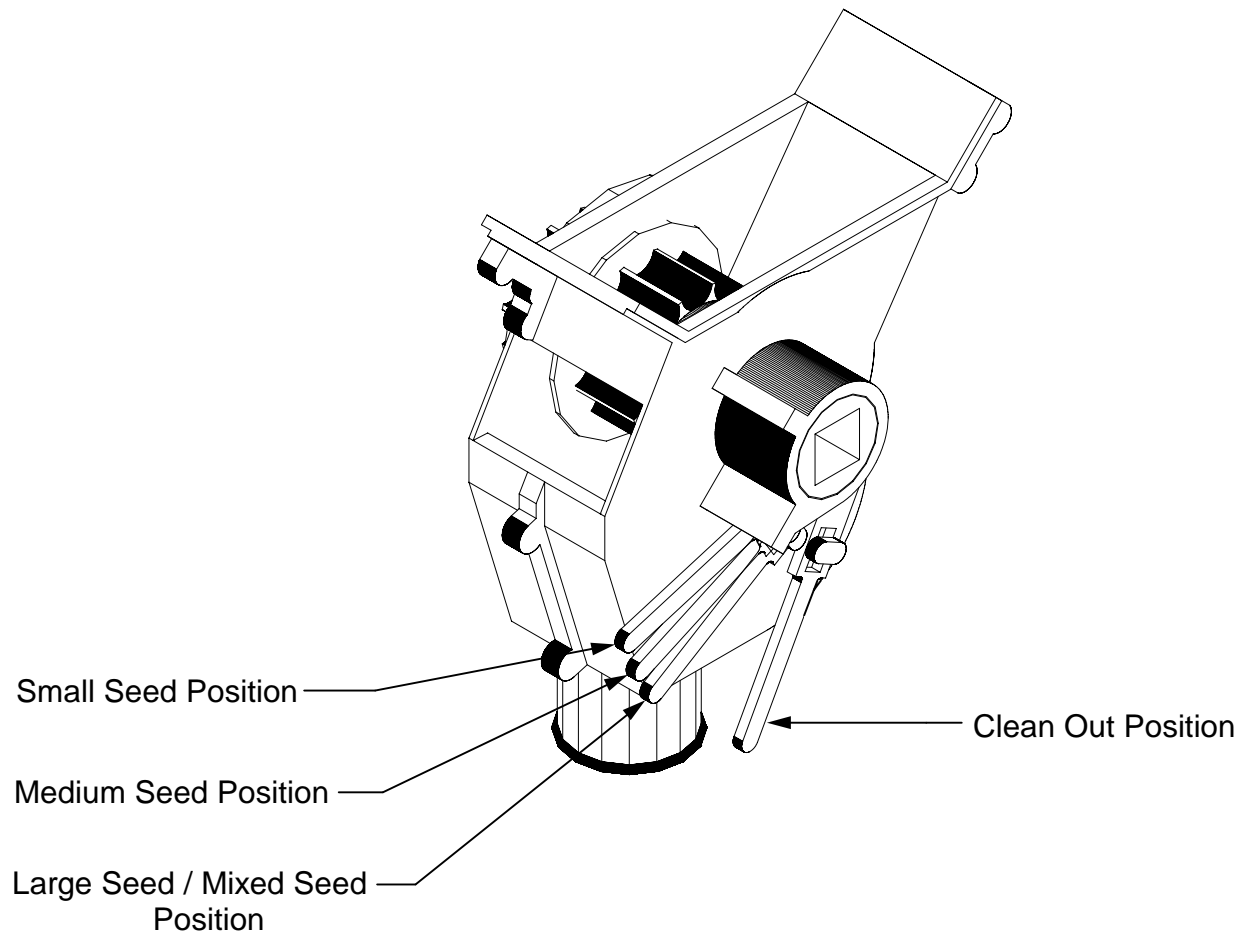

PLANTING DEPTH ADJUSTMENTS

Your Schmeiser Vineyard Drill is designed to run level to the ground when in planting position. Minor adjustments may be required to achieve the desired seed placement.

Before making any adjustments, insure that unit is level with ground, and feed cups, seed tubes and drives are working properly and free from foreign material.

PRESSWHEEL - OPENER LINKAGE DEPTH ADJUSTMENT

The depth of each opener is controlled by the height of the press wheel. To change the seeding depth of the opener, pull and move the handle located directly above each press wheel until the seeding depth is correct. A self-locking spring clip holds the knob at your setting to maintain the proper depth.

- For shallower seeding, slide adjustment handles toward drill.
- For deeper seeding, slide adjustment handles away from drill.

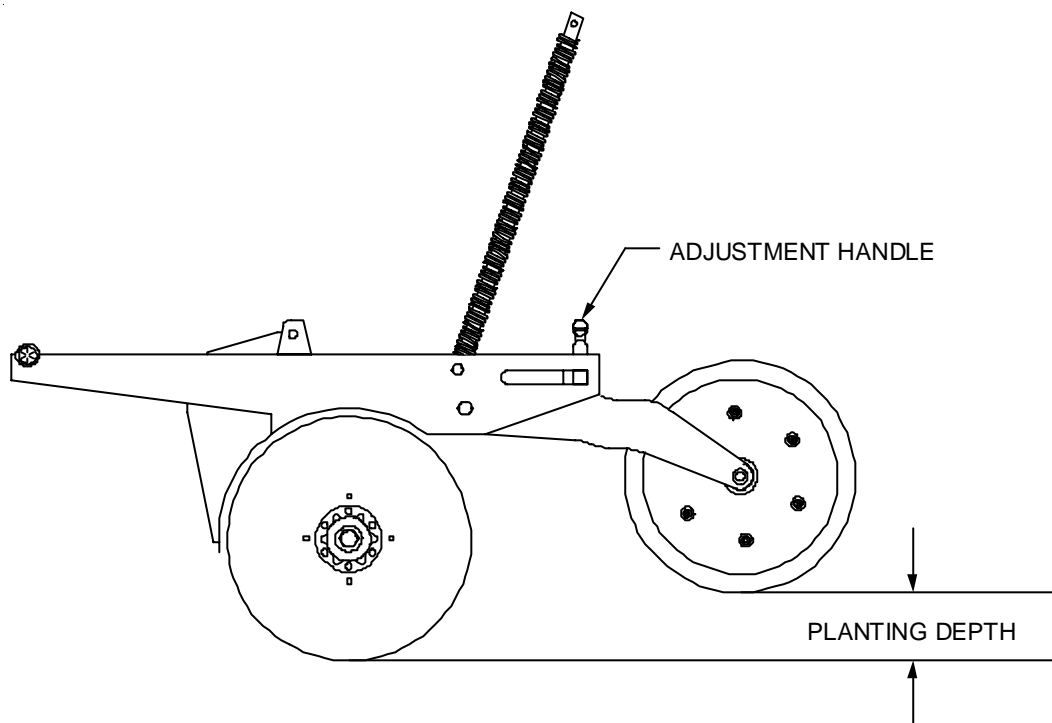

Check the top of the spring rods to see that they are extended approximately 2" above their spring rod casting. This is a general dimension and may vary with the spring rod down-pressure that you require for different soil conditions and planting depths. If you require more downward float on your openers, you may want to increase this dimension. Keep in mind that when this dimension is increased your upward motion is decreased, limiting the vertical travel of the openers for running over rocks and other foreign objects.

- **IMPORTANT: If your opener's vertical travel is decreased, considerable damage may occur to your openers.**

DISK OPENER SPRING PRESSURE SETTING

Each opener spring can be adjusted for down pressure. This is useful when penetrating hard soil and for planting in tractor tire tracks. The springs allow the openers to follow uneven profile terrain. To adjust the pressure, remove the "W" clip at the bottom of the spring and place it in a higher hole in the spring rod for more pressure, and in a lower hole for less pressure (see below). If too much penetration is achieved at the lowest pressure setting, the "W" clips may be completely removed.

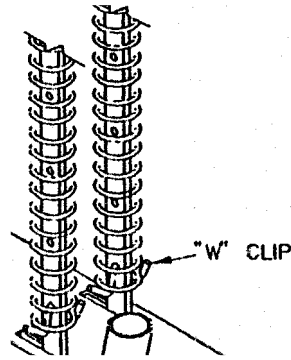

Minimum Pressure

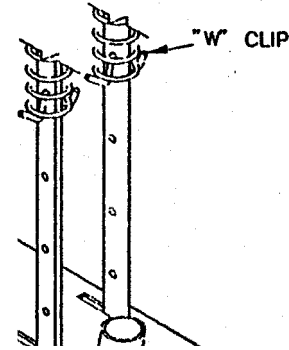

Maximum Pressure

After planting depth is adjusted and opener spring pressure is set, lower drive wheel, insuring good ground contact for proper seed flow.

DRIVE WHEEL ADJUSTMENT

In order to adjust the height of your drive wheel, loosen the two set screws located on the front of the main frame. Move the drive wheel either up or down to desired height. Be certain to tighten both set screws after adjusting.

NOTE: Adjust the drive wheel height only after ensuring that unit is level and the planting depth has been calibrated.

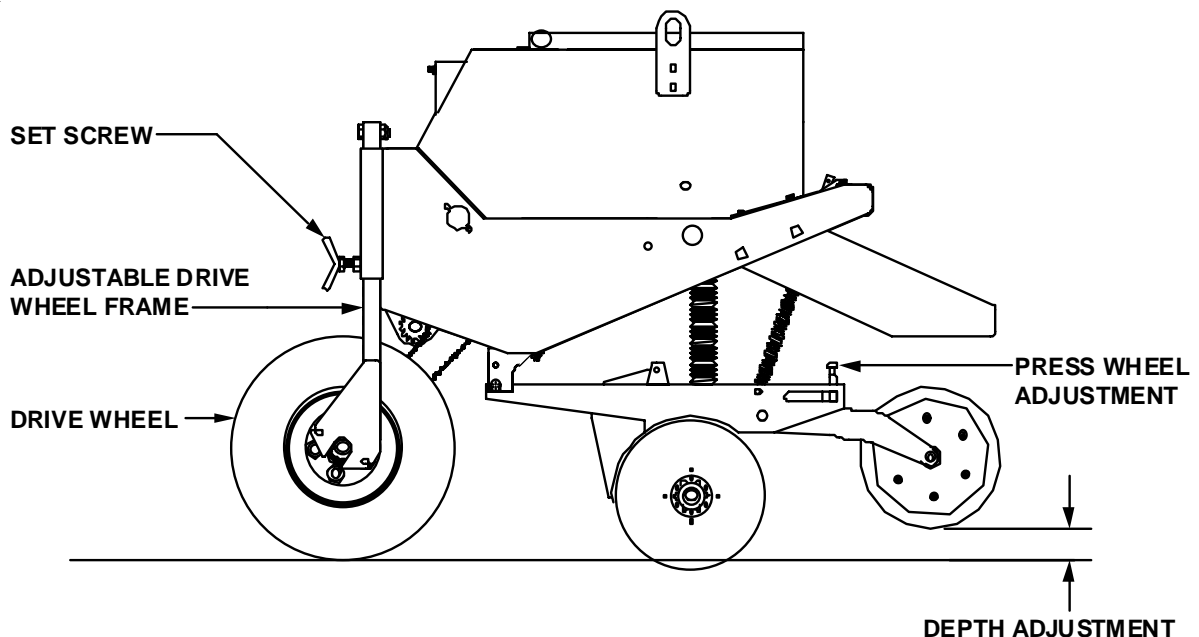

SPROCKET AND CHAIN ASSEMBLIES

DRIVE CHAIN

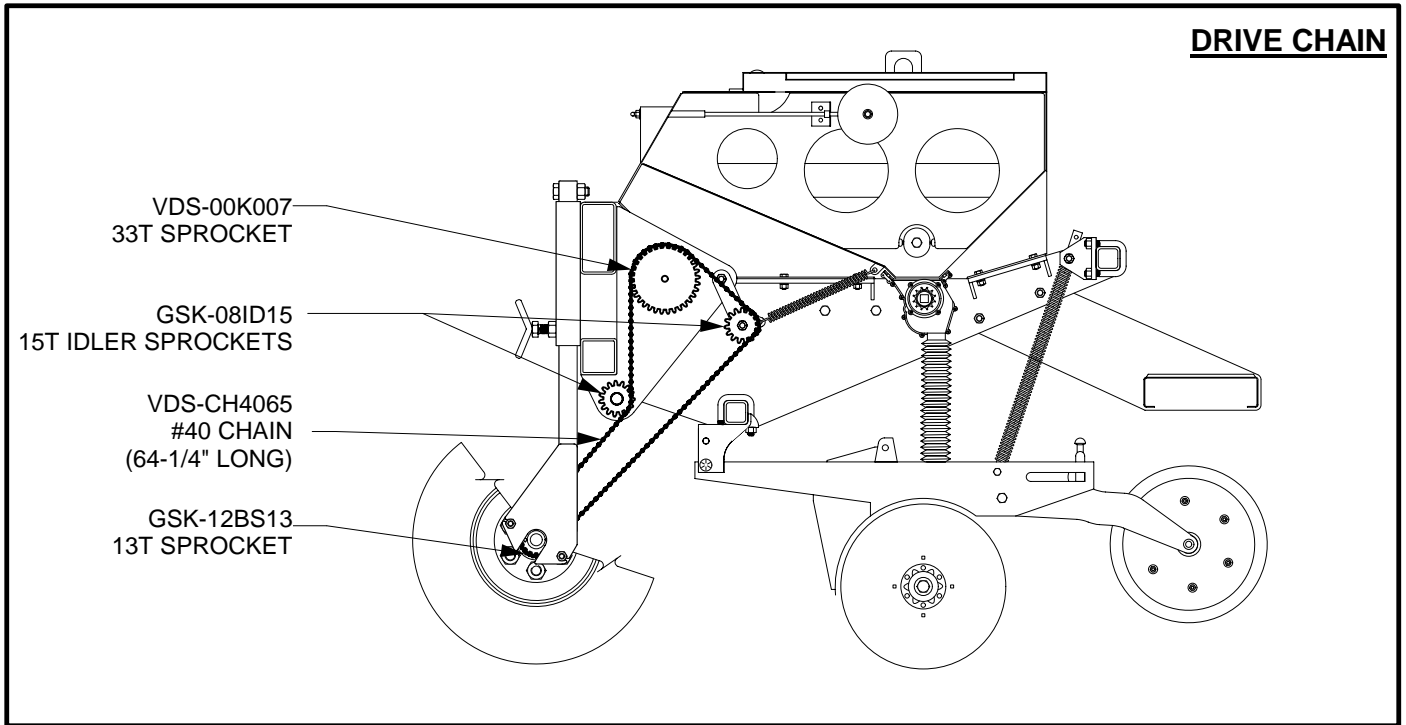

END CHAIN

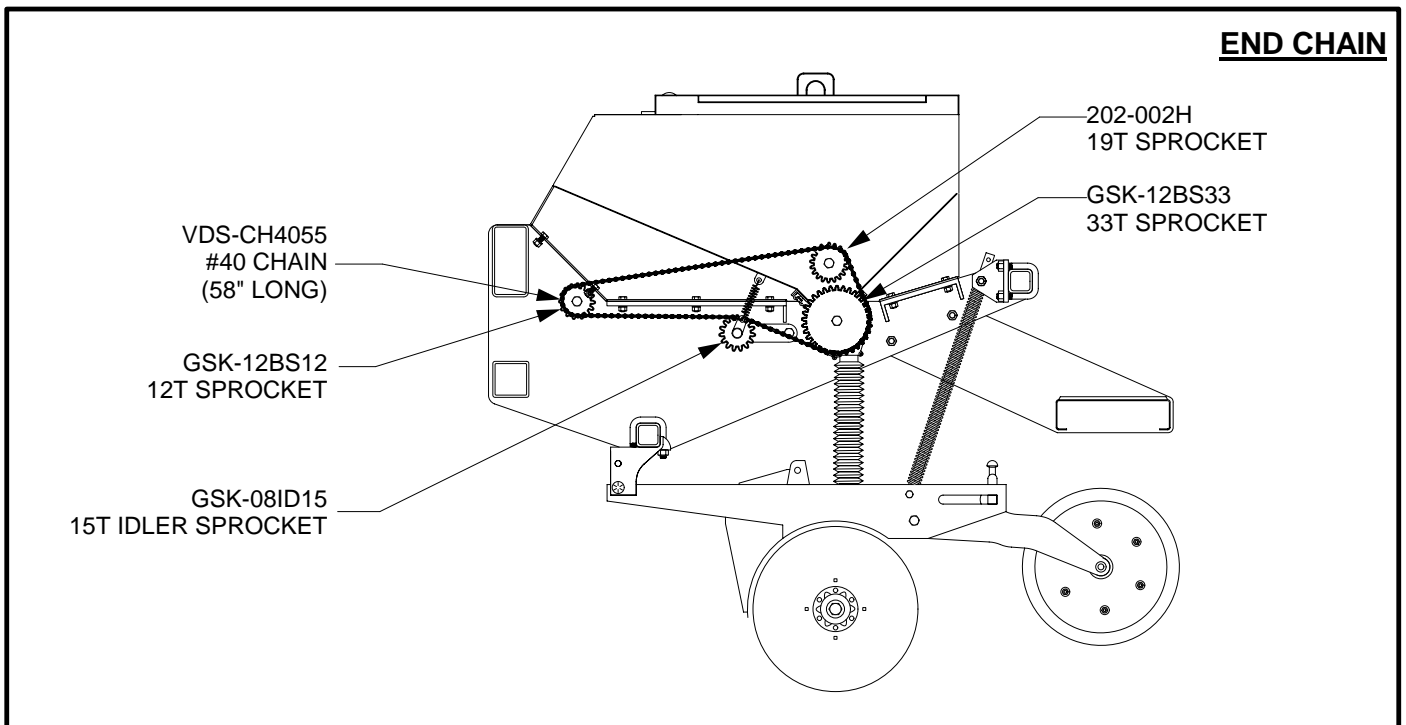

VINEYARD DRILL BOX ASSEMBLY

<u>Ref. No.</u>	<u>Old Part No.</u>	<u>New Part No.</u>	<u>Description</u>
1.	VD4-C	VDS-48C000	4' Vineyard Drill Lid Weldment
	VD5-C	VDS-60C000	5' Vineyard Drill Lid Weldment
	VD6-C	VDS-72C000	6' Vineyard Drill Lid Weldment
2.	-----	FWASHER-05	Washer, Flat 5/16"
3.	-----	LWASHER-05W	Washer, Wave Spring 5/16"
4.	-----	NYNUT-05NC	Nut, Hex Nylock 5/16" - 18
5.	VD-C-07	VDS-00C007	Lid Latch-Handle
6.	817-033D	817-033D	Lid Latch Grip
7.	VD-M	VDS-00M000	Lid Hinge Weldment
8.	VD-C-08	VDS-00C008	Lid Latch - Lower Arm
9.	-----	CSNC505016	Bolt, Hex Head 5/16" - 18 x 1" Long Gr 5 Plated
10.	VD-C-12	VDS-00C012	Lid Latch - Lower Latch Bushing
11.	VD-C-09	VDS-00C009	Lid Latch - Upper Arm
13.	VD-L-01	VDS-00L000	Float Indicator Assembly
14.	VD-L-04	VDS-00L004	Float Indicator - Coupling
15.	-----	CSNC506016	Bolt, Hex Head 3/8" - 16 x 1" Long Gr. 5 Plated
16.	VD-B-10	VDS-00B010	Sprocket Cover Plate
17.	VD4-B	VDS-48B000	4' Seedbox
	VD5-B	VDS-60B000	5' Seedbox
	VD6-B	VDS-72B000	6' Seedbox
18.	-----	LWASHER#10S	Washer, Internal Star #10 Plated
19.	-----	HXNUT#10NC	Nut, Hex #10-24 Plated
20.	VD-C-10	VDS-00C010	Rear Lid Latch Hook
21.	-----	CSNC#10012R	Screw, Round Head #10-24 x 3/4" Long Plated
22.	-----	HXNUT-05NC	Nut, Hex 5/16" - 18 Gr. 2 Plated
23.	-----	LWASHER-05	Washer, Lock Spring 5/16" Plated
24.	-----	FWASHER-05	Washer, Flat 5/16" Plated
25.	-----	HXNUT208NC	Nut, Hex 1/2" - 13 Gr. 2 Plated
26.	-----	LWASHER-08	Washer, Lock Spring 1/2" Plated
27.	-----	LWASHER-06	Washer, Lock Spring 3/8" Plated
28.	-----	HXNUT-06NC	Nut, Hex 3/8" - 16" Gr. 5
29.	VD-B-09	VDS-00B009	Vineyard Drill Lift Hooks
30.	-----	CSNC508016	Bolt, Hex Head 1/2" - 13 x 1" Long Gr. 5
31.	-----	GBR-12FP03	3/4" Flangette Plates
32.	-----	GBR-12BI02	Bearing 3/4" Bore with Collar
33.	-----	CSNC504024	Bolt, Hex Head 1/4" - 20 x 1-1/2" Long Gr. 5
34.	202-002H	202-002H	Sprocket, Speed Change 19T
35.	-----	NYNUT-04NC	Nylon Hex Lock Nut, 1/4" - 20 Plated
36.	-----	CBNC505012	Bolt, Carriage 5/16" x 3/4" Long Gr. 5
37.	VD4-G-09	VDS-48G200	4' Agitator Weldment
	VD5-G-09	VDS-60G200	5' Agitator Weldment
	VD6-G-09	VDS-72G200	6' Agitator Weldment
38.	-----	BALL-64OD	Float Indicator - Float
39.	VD-L-03	VDS-00L100	Float Indicator - Shaft Bracket - Weldment
40.	-----	GMB-CHFLIN	Float Indicator - Chain 10 3/4" Long
41.	-----	SHOOK-16	S - Hook, 1"
42.	-----	LCOLLAR-05	Lock Collar, 5/16"
43.	-----	FWASHER-06	3/8" Flat Washer
44.	-----	CSNC505024	Bolt, Hex Head 5/16" x 1 1/2"
45.	-----	OMC1	Owners Manual Canister

VINEYARD DRILL / S-TINE SEEDER BOX ASSEMBLY

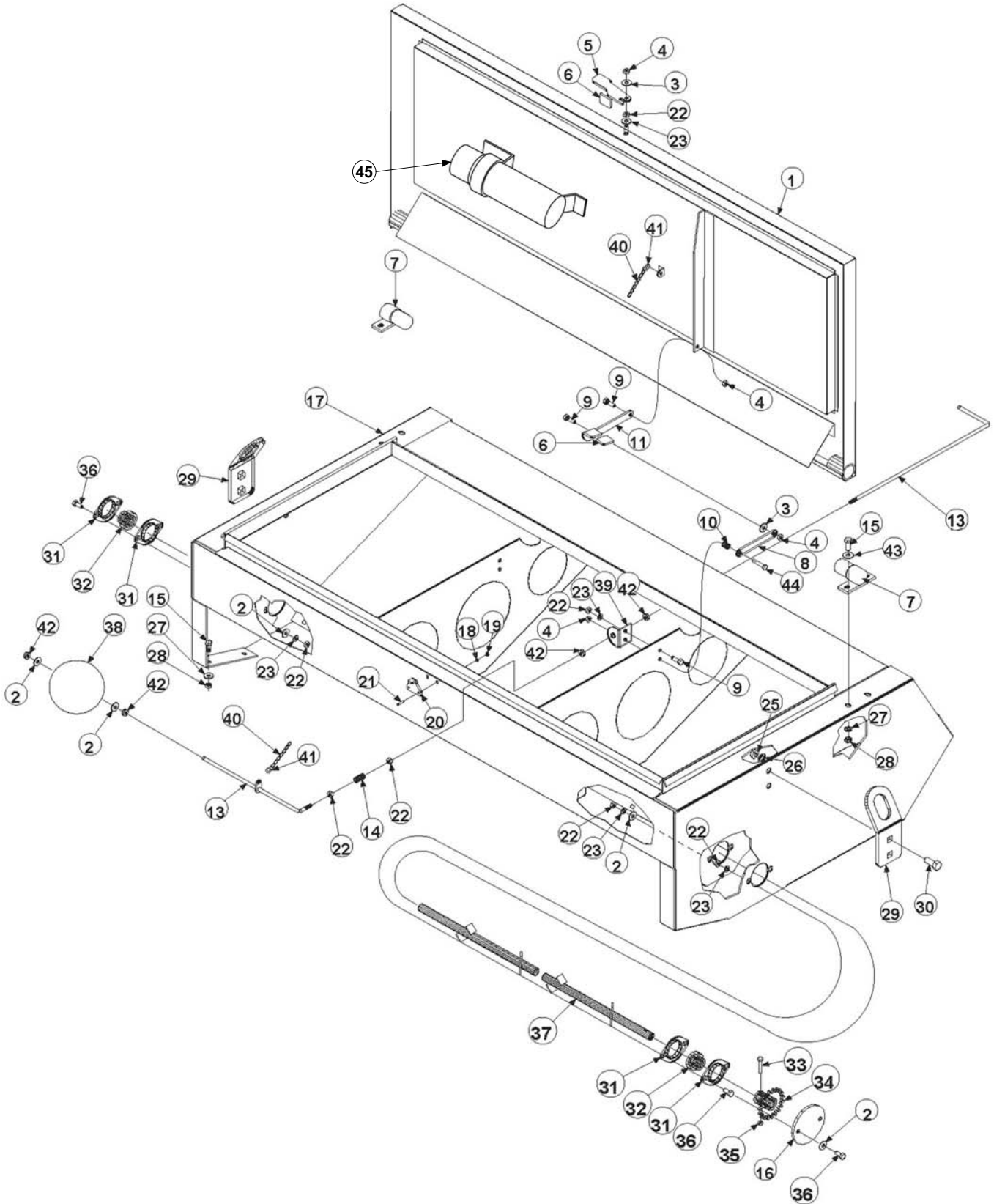

FEEDER CUP AND DRIVE COMPONENTS

<u>Ref No.</u>	<u>Old Part No.</u>	<u>New Part No.</u>	<u>Description</u>
1.	VD-B	VDS-48B000	4' Box Weldment
		VDS-60B000	5' Box Weldment
		VDS-72B000	6' Box Weldment
2.	VD-K-01	VDS-48K001	4' Cup Tray
		VDS-60K001	5' Cup Tray
		VDS-72K001	6' Cup Tray
3.	VD-K-03	VDS-00K003	Pivot Handle Adjustment Mount
4.	VD-K-02	VDS-00K100	Seed Rate Adjustment Handle
5.	109-025H	109-025H	Adjustment Lock Plate
6.	VD-K-04	VDS-00K004	Gauge Mounting Plate
8.	VD-K-07	VDS-SRINDP	Seed Rate Indicator Plate
9.	-----	CSNC#10008R	Screw, Round Head #10 x 1/2"
11.	-----	LWASHER#10S	Washer, Internal Star #10
12.	-----	HXNUT#10NC	Nut, Hex #10
16.	-----	CSNC506016	Bolt, Hex Head 3/8" - 16 x 3/4" Long
17.	-----	LWASHER-06	Washer, Lock 3/8" Plated
18.	-----	FWASHER-06	Washer, Flat 3/8" Plated
19.	109-069D	109-069D	Adjustment Handle Pivot Bushing
20.	-----	GPN-03X32C	Pin, Cotter 3/16" x 1-1/4" Long Plated
21.	308-015D	308-015D	Seed Adjustment Bearing Ring Pivot
22.	-----	FWASHER-05	Washer, Flat 5/16" USS Plated
23.	-----	NYNUT-05NC	Nut, Nylon Self Locking Hex 5/16" - 18
24.	-----	HXNUT-04NC	Nut, Hex 1/4" - 20
25.	-----	CBNC504012	Bolt, Hex Carriage 1/4" - 20 x 3/4" Long
26.	-----	WGNUT-08NC	Nut, Wing 1/2" - 13 Plated
27.	-----	FWASHER-10	Washer, Flat 5/8" Plated
28.	-----	FWASHER-08	Washer, Flat 1/2"
29.	-----	CBNC508020	Bolt, Hex Carriage 1/2" x 1-1/4"

FEEDER CUP AND DRIVE COMPONENTS

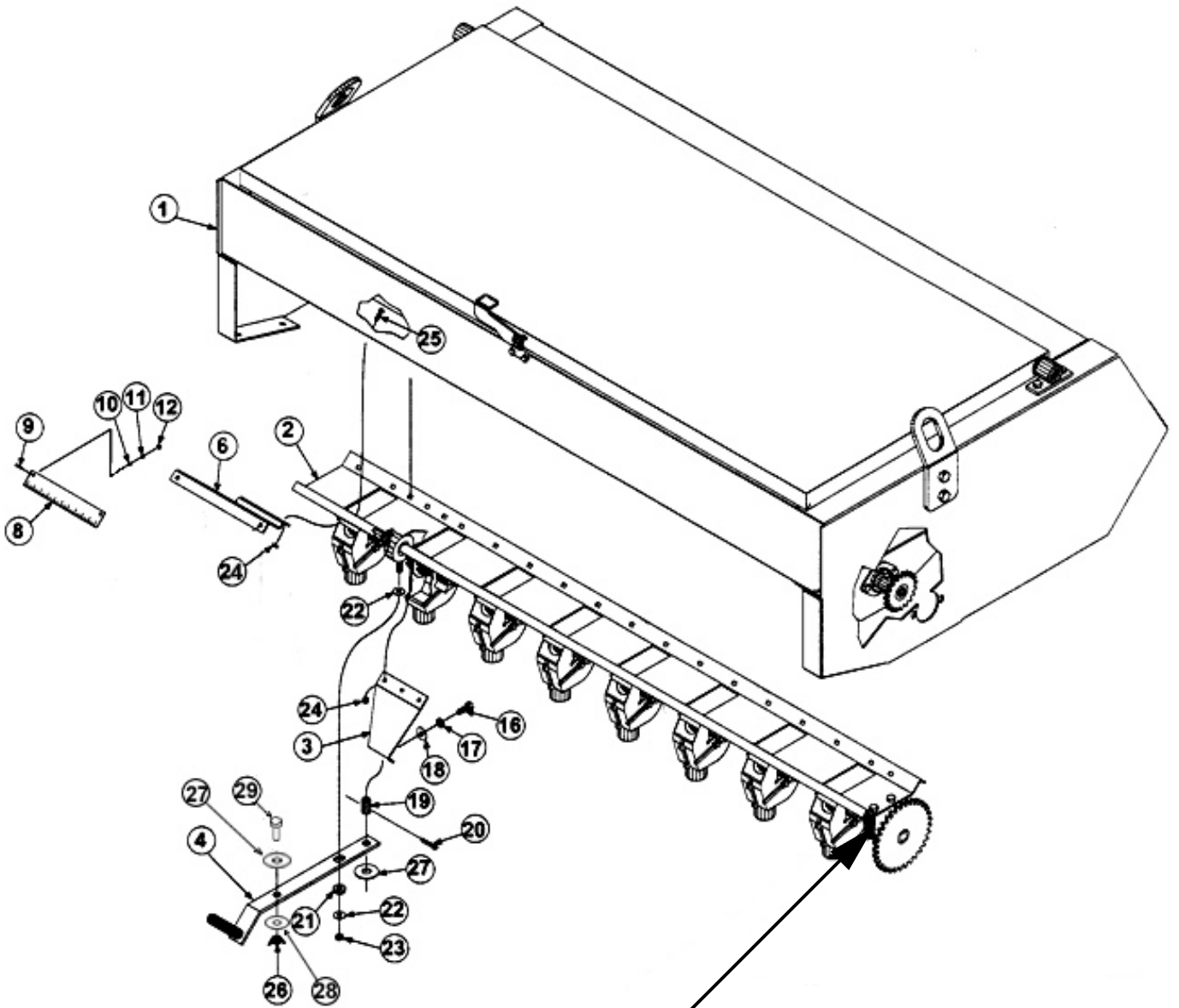

**INSURE THAT SQUARE SEED CUP
SHAFT IS LUBRICATED WHERE SHAFT
GOES THROUGH CUP DRIVE BEARING.**

FEEDER CUP ASSEMBLY

<u>Ref. No.</u>	<u>Old Part No.</u>	<u>New Part No.</u>	<u>Description</u>
1.	VD4-K-01	VDS-48K001	4' Seed Cup Tray
	VD5-K-01	VDS-60K001	5' Seed Cup Tray
	VD6-K-01	VDS-72K001	6' Seed Cup Tray
2.	-----	CBNC504012	Bolt, Carriage 1/4" - 20 x 3/4" Long
3.	182-022D	890-350C	Feeder Cup Shaft Locking Collar
4.	801-035C	801-035C	Screw, Set Knurled Point 5/16" - 18 x 3/8" Long
5.	-----	LWASHER-04	Washer, Lock 1/4"
6.	803-006C	HXNUT-04NC	Nut, Hex 1/4" - 20 Gr.5 Plated
7.	VD-K-07	118-438D	Spacer Tube 3-9/16" Long
8.	308-004S	308-004S	Sprocket Shaft Adjustment Bearing Assembly
9.	890-190C	890-190C	Powder Metal Sprocket
10.	817-075C	817-075C	Seed Cup Assembly
11.	817-071C	817-071C	Seed Cup Adjustment Handle
12.	817-074C	817-074C	Cup Sleeve
13.	804-031C	804-031C	Washer, Retaining
14.	800-004C	800-004C	Ring, Snap External 1-3/16"
15.	800-107C	800-107C	Ring, Snap Internal 2.165
16.	822-103C	822-103C	Bearing, 30mm B x 55mm OD
17.	118-336D	118-336D	Cup Drive Bearing Housing
18.	VD-K-07	VDS-00K007	Cup Drive Sprocket Weldment
19.	VD4-K-05	VDS-48K005	4' Seed Cup Shaft
	VD5-K-05	VDS-60K005	5' Seed Cup Shaft
	VD6-K-05	VDS-72K005	6' Seed Cup Shaft
20.	-----	CSNC506012	Bolt, Hex Head 3/8" - 13 x 3/4" Gr.5
21.	-----	LWASHER-08	Washer, Lock Spring 1/2" Plated
	176-031V	176-031V	Cup Drive Housing Assembly Includes 1 Each of Items 15 through 17

FEEDER CUP ASSEMBLY

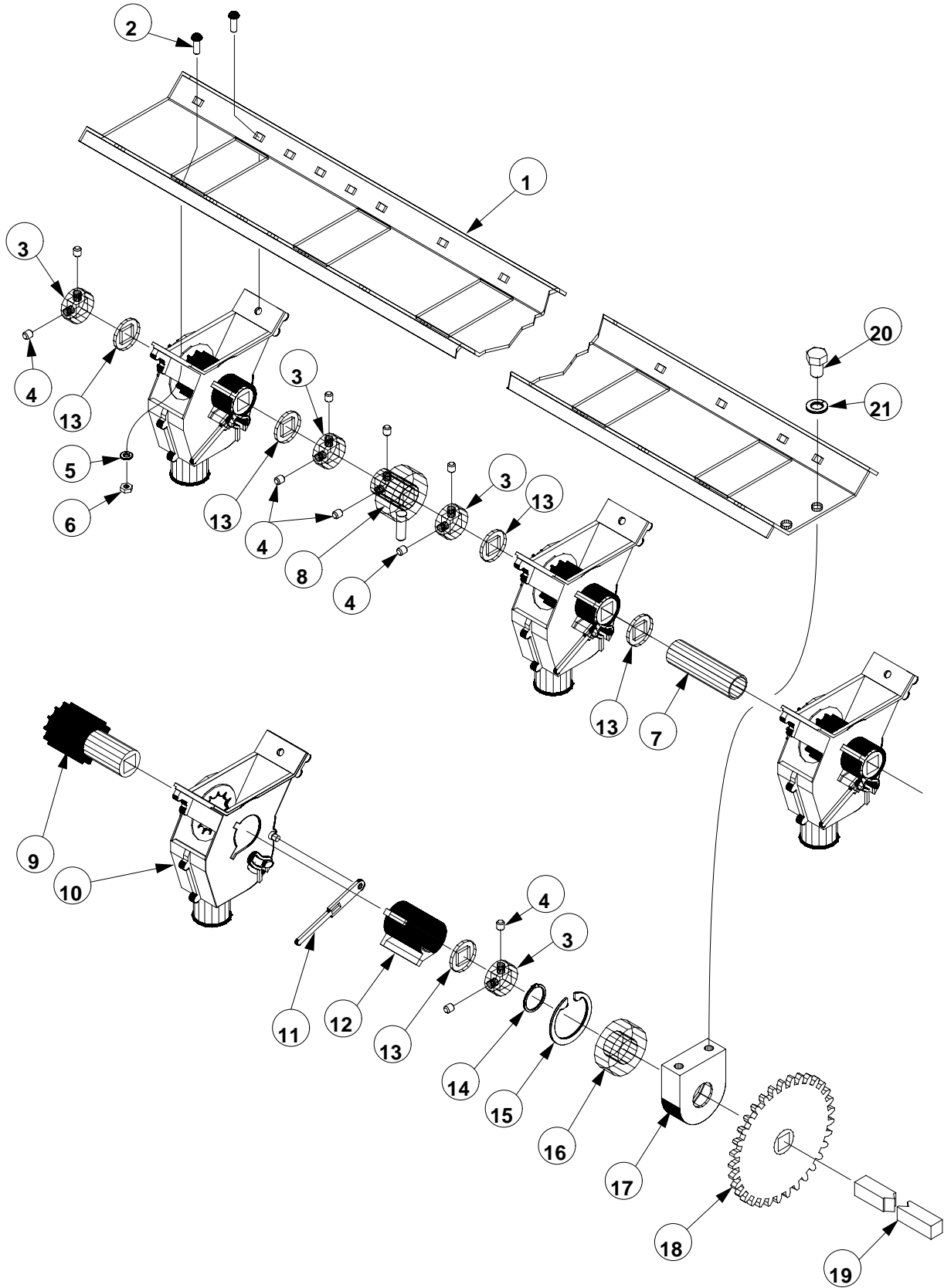

MAIN FRAME, WHEEL FRAME & WALKBOARD ASSEMBLIES

<u>Ref No.</u>	<u>Part No.</u>	<u>Description</u>	<u>Qty</u>
1	VDS-30A000	2-1/2' Main Frame	1
	VDS-36A000	3' Main Frame	1
	VDS-48A000	4' Main Frame	1
	VDS-60A000	5' Main Frame	1
	VDS-72A000	6' Main Frame	1
2	VDS-30H000	2-1/2' Walk Board	1
	VDS-36A000	3' Walk Board	1
	VDS-48A000	4' Walk Board	1
	VDS-60H000	5' Walk Board	1
	VDS-72H000	6' Walk Board	1
3	VDS-00E100	Drive Wheel H-Frame	1
4	GSR-17112T	7" Tension Spring	1
5	GWT-801004	20" x 8" x 10" Tire W/ Wheel	1
6	VDS-00D100	Wheel Shaft	1
7	GBR-20FL01	1-1/4" Flange Bearing	2
8	GPN-18CA12	CAT. 1&2 Pull Pin	2
9	GPN-070LYN	7/16" Lynch Pin	2
10	VDS-00J100	Set Screw Weldment 3/4" x 1-1/2" (Vineyard Drills)	2
	VDS-00J200	Set Screw Weldment 3/4" x 2-1/2"(No-Till Drills)	2
11	CSNC512040	3/4" x 2-1/2" NC Cap Screw	1
12	LWASHER-12	3/4" Lock Washer	5
13	HXNUT-12NC	3/4" NC Hex Nut	5
14	CSNC508028	1/2" x 1-3/4" NC Cap Screw	4
15	LWASHER-08	1/2" Lock Washer	4
16	HXNUT-08NC	1/2" NC Hex Nut	4
17	CSNF508020	1/2" X 1-1/4" NF Cap Screw	5
18	WHN-08NFWN	1/2" Lug Nut	5
19	CBNC512032	3/4" x 2" NC Carriage Bolt	4
20	GSK-12BS13	13 Tooth Sprocket	1
21	VDS-00G010	Sprocket Key	1

MAIN FRAME, WHEEL FRAME & WALKBOARD ASSEMBLIES

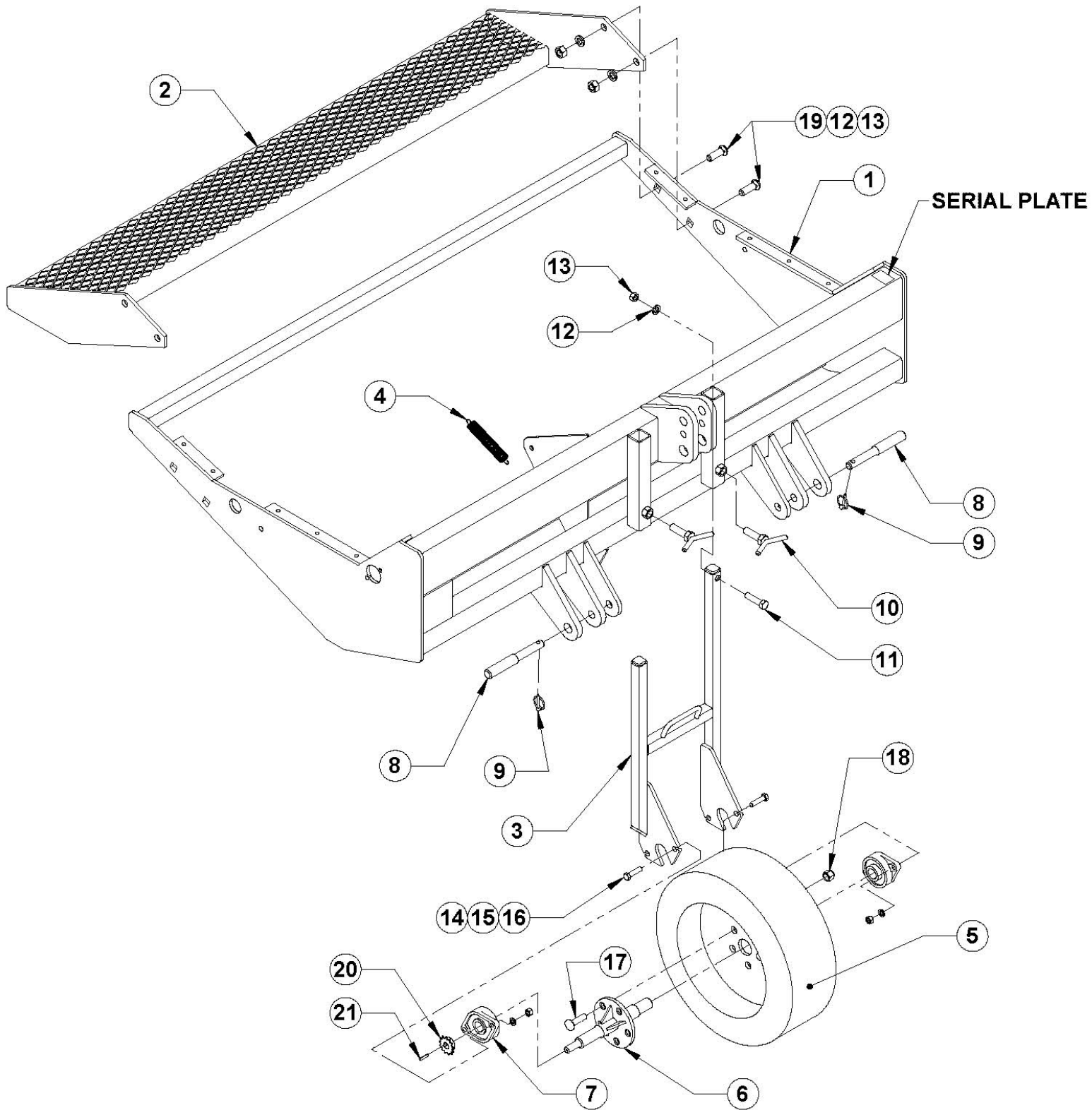

JACK SHAFT, SPROCKET, IDLER & BEARING ASSEMBLIES

<u>Ref No.</u>	<u>Old Part No.</u>	<u>New Part No.</u>	<u>Description</u>	<u>Qty.</u>
1.	VD4-G-06	VDS-48G006	4' Jack Shaft	1
	VD5-G-06	VDS-60G006	5' Jack Shaft	1
	VD6-G-06	VDS-72G006	6' Jack Shaft	1
2.	VD-G-02	VDS-00G002	End Plate Tensioner Arm	1
3.	VD-G-01	VDS-00G001N	Center Tensioner Arm & Spring Anchor	1
4.	VD-G-03b	VDS-00G102	Bushing, 13/16" Long	2
5.	VD-G-03	VDS-00G100	Spring Anchor	1
6.	VD-G-04	VDS-00G004	Bushing, 1/2" Long	2
7.	VD-G-05	VDS-00G005	Bushing, 1-1/4" Long	1
8.	VDB-01	GSR-17112T	7" Tension Spring	1
9.	VDB-02	GSR-10040T	2-1/2" Tension Spring	1
10.	VDB-33TS	GSK-12BS33	33 Tooth Sprocket	1
11.	VDB-15I	GSK-08ID15	15 Tooth Idlers	3
12.	VDB-12TS	GSK-12BS12	12 Tooth Sprocket	1
13.	VDB-03	GBR-12BI02	Bearing Insert with Collar, 3/4"	2
14.		CBNC505016	5/16" x 1" Carriage Square Neck Bolts	4
15.		CSNC508032	1/2" x 2" Hex Head Gr 5 z/p Bolt	1
16.		CSNC508040	1/2" x 2-1/2" Hex Head Gr 5 z/p Bolt	2
17.		CSNC508056	1/2" x 3-1/2" Hex Head Gr 5 z/p Bolt	2
18.		LWASHER-05	5/16" Lock Washers	4
19.		LWASHER-08	1/2" Lock Washers	3
20.		FWASHER-08	1/2" Flat Washer	3
21.		HXNUT-05NC	5/16" Hex Nuts	4
22.		HXNUT-08NC	1/2" Hex Nuts	3
23.		NYNUT-08NC	1/2" Nylon Locknuts	2
24.	VD-G-10	VDS-00G010	Sprocket Key	2
25.		VDS-CH4065	Drive Chain Kit 64 1/4" Long	1
26.		VDS-CH4055	End Chain Kit 58" Long	1
27.		-----	Set Screw 3/16"	2
28.	118-226S	118-226S	Feeder Cup Bearing Assembly	1
29.		202-002H	19 Tooth Speed Change Sprocket	1
30.		FWASHER-05	5/16" Flat Washer	4
31.		GBR-12FP03	3/4" Stamped Flangette Plates (Pair)	2

JACK SHAFT, SPROCKET, IDLER & BEARING ASSEMBLIES

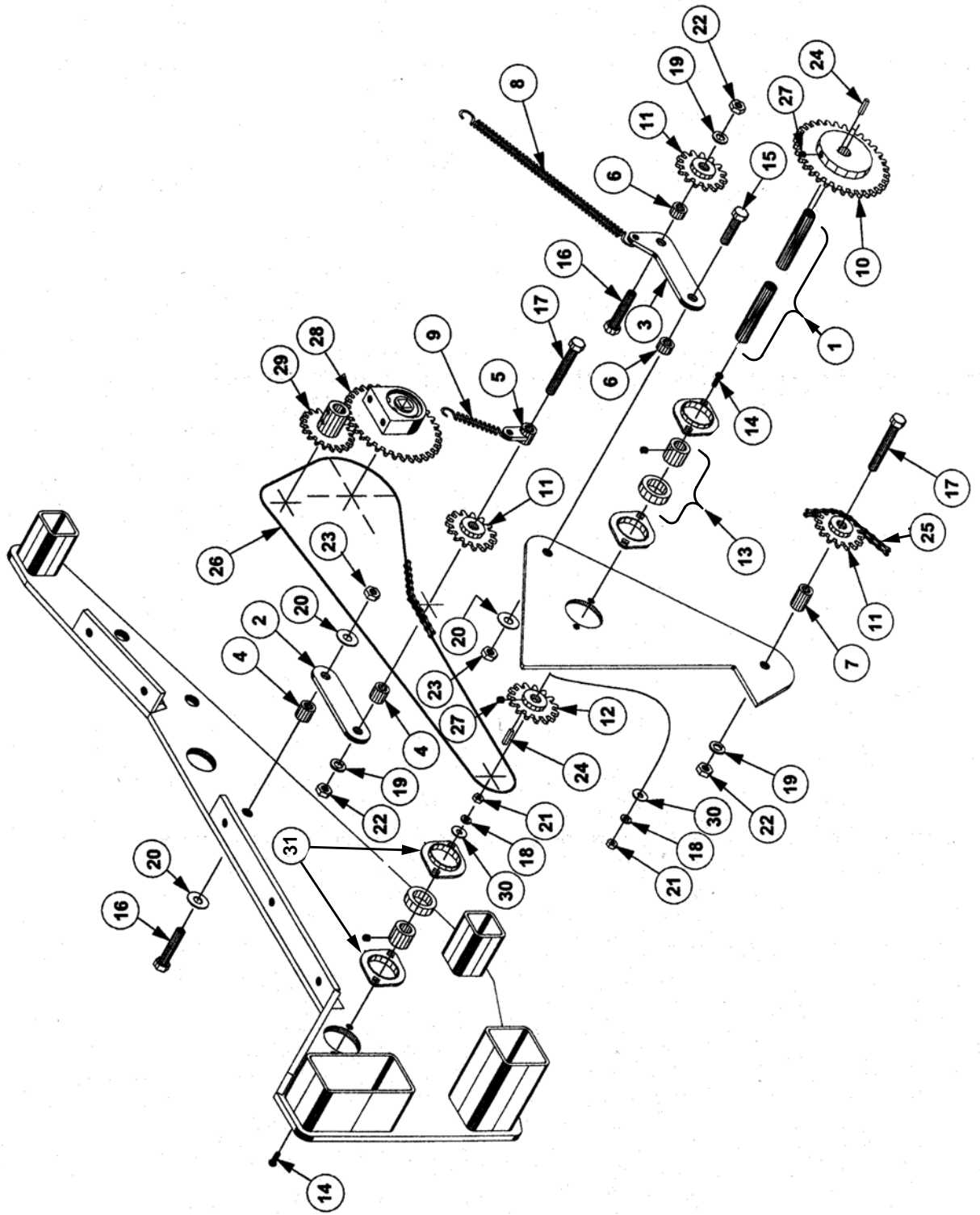

STRAIGHT ARM DOUBLE DISK OPENER ASSEMBLY

<u>Ref.</u>	<u>Old Part No.</u>	<u>New Part No.</u>	<u>Description</u>
1.	806-004C	806-004C	U-Bolt 3/8-16 X 2 X 2 3/4
2.	804-013C	LWASHER-06	Washer Lock Spring 3/8 Plt
3.	803-014C	HXNUT-06NC	3nut Hex 3/8-16 Plt
4.	121-025D	121-025D	Spring Rod Casting Clip
5.	812-012C	812-012C	Casting Double Spring Rod
6.	121-011A	121-011A	Spring Casting Mtg Ass'y
7.	121-133D	121-133D	Straight Arm Opener Spring Rod
8.	802-004C	CSNC504012	Hhcs 1/4-20x3/4 Gr5
9.	804-006C	LWASHER-04	Washer Lock Spring 1/4 Plt
10.	803-006C	HXNUT-04NC	Nut Hex 1/4-20 Plt
11.	807-118C	807-118C	11spring Comp 13/16idx.156wx19.5
12.	107-027D	107-027D	Disc Spring Bar Wire Clip
13.	802-427C	802-427C	Hfs 3/8-16x3 5/8 Spthd
14.	804-012C	804-012C	Washer Flat 3/8 Sae Plt
15.	107-113D	107-113D	D.D. Slotted Scraper
16.	802-015C	CSNC506016	Rhsnb 3/8-16x1 Gr5
17.	803-209C	803-209C	Nut Flange Lock 3/8-16 Plt
18.	804-040C	804-040C	Washer Mach 1.19 X .63 X 18ga
20.	188-001V	188-001V	Bearing Aa205dd
21.	107-112D	107-112D	Bearing Flange-3/16 Dia Holes
22.	800-212C	800-212C	Rivet,Button Head 1/4 X 9/16
23.	107-133S	107-135S	D.D. W/ 205 Brg Assy-Plt Flng
24.	107-111D	107-111D	Dd Brg Flange Dust Cover
25.	802-228C	CSNC510024	Hhcs 5/8-11x1 1/2 Gr5 Nyl
26.	121-703H	121-703H	Opener Weldment - Short
27.	817-314C	817-314C	Opener Seed Tube, Plastic
28.	801-002C	CSNC#10008	Screw Hex Slit #10-16x 1/2".Thd Ct
29.	800-008C	800-008C	Clamp Hose 1 1/2 No. 24
30.	816-114C	816-114C	Seed Hose 30 Ribs X 7 1/2 Lg
31.	800-009C	800-009C	Clamp Hose 1 5/8 No. 26
32.	802-121C	CBNC508088	1/2 X 5-1/2 NC Carriage Bolt Gr.5
33.	817-084C	817-084C	Parallel Arm Pivot Bushing
34.	142-198D	142-198D	Straight Arm Opener Pivot Pipe
35.	803-169C	NYNUT-08NC	Nut Hex Flg. Lock 1/2-13 Plt.
36.	122-242S	122-242S	Seed Flap & Hex Clip, Seedlok
38.	816-302C	816-302C	Seed Flap, Rubber, Seed-Lok
39.	806-109C	UBNC08X33S	U-Bolt 1/2-13 2-1/16W X 3D
40.	142-194D	107-116D	Straight Arm Opener Mount w/2" drop
41.	803-037C	HXNUT-08NC	Nut Hex Whiz 1/2-13 Plt

STRAIGHT ARM DOUBLE OPENER ASSEMBLY

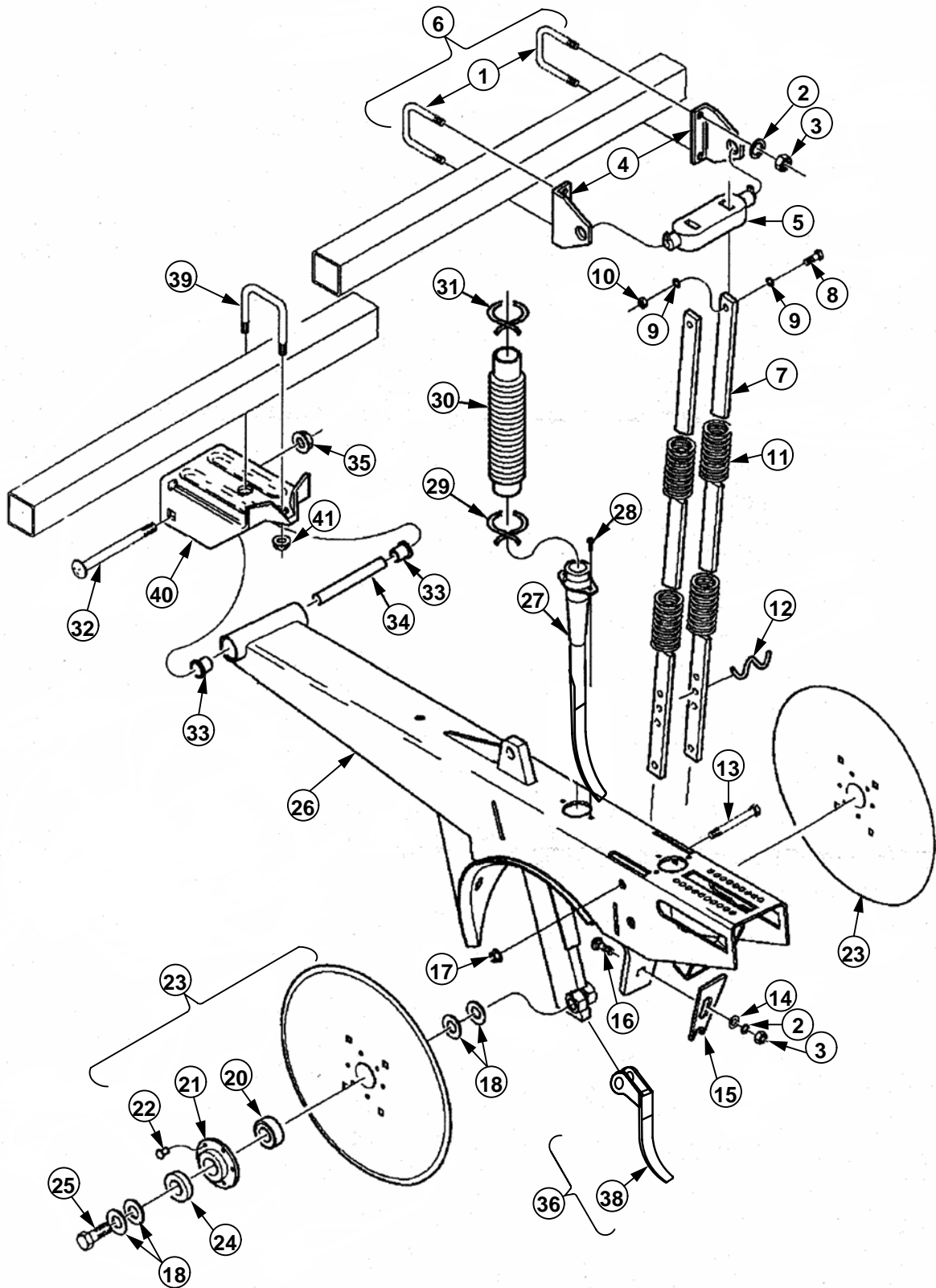

2” x 13” SMOOTH CROWN PRESS WHEEL

<u>Ref. No.</u>	<u>Old Part No.</u>	<u>New Part No.</u>	<u>DESCRIPTION</u>
1.	802-058C	CSNC510040	HHCS 5/8 – 11 x 2 ½ GR5
2.	804-022C	LWASHER-10	Washer Lock Spring 5/8 Plt
3.	803-088C	NYNUT-04NC	Nut Hex Lock ¼ - 20 Flg
4.	817-296C	817-296C	2 x 13 Press Wheel Rim Half
5.	822-170C	822-170C	Bearing Press Wheel Assembly
6.	814-159C	814-159C	2 x 13 Press Wheel Tire
7.	802-617C	CBNC504024	HHFS ¼ -20 x 1 ½ GR 5 Carriage Bolt
8.	814-157C	814-157C	2 x 13 Press Wheel Assembly
9.	199-042D	199-042D	Universal Press Wheel Arm 2&3 x 13
10.	817-084C	817-084C	Parallel Arm Pivot Bushing
11.	198-137D	198-137D	Press Wheel Pivot Tube
12.	805-154C	805-154C	Pin Clevis 3/8 x 2 1/8 Usable
13.	807-106C	807-106C	Spring .540 O.D. x 1 ¼ x .054W
14.	817-347C	817-347C	Opener Trunnion
15.	802-421C	CBNC508064	HFS ½ - 13 x 3-3/4 Carriage Bolt
16.	803-169C	NYNUT-08NC	Nut Hex Flg. Lock ½ - 13 Plt
17.	817-328C	817-328C	T – Handle Assembly
18.	805-186C	805-186C	Pin Roll 5/32 x 5/8 Plt
19.	122-202S	122-202S	PW Adjustment Trunnion Assy

2" x 13" SMOOTH CROWN PRESS WHEEL

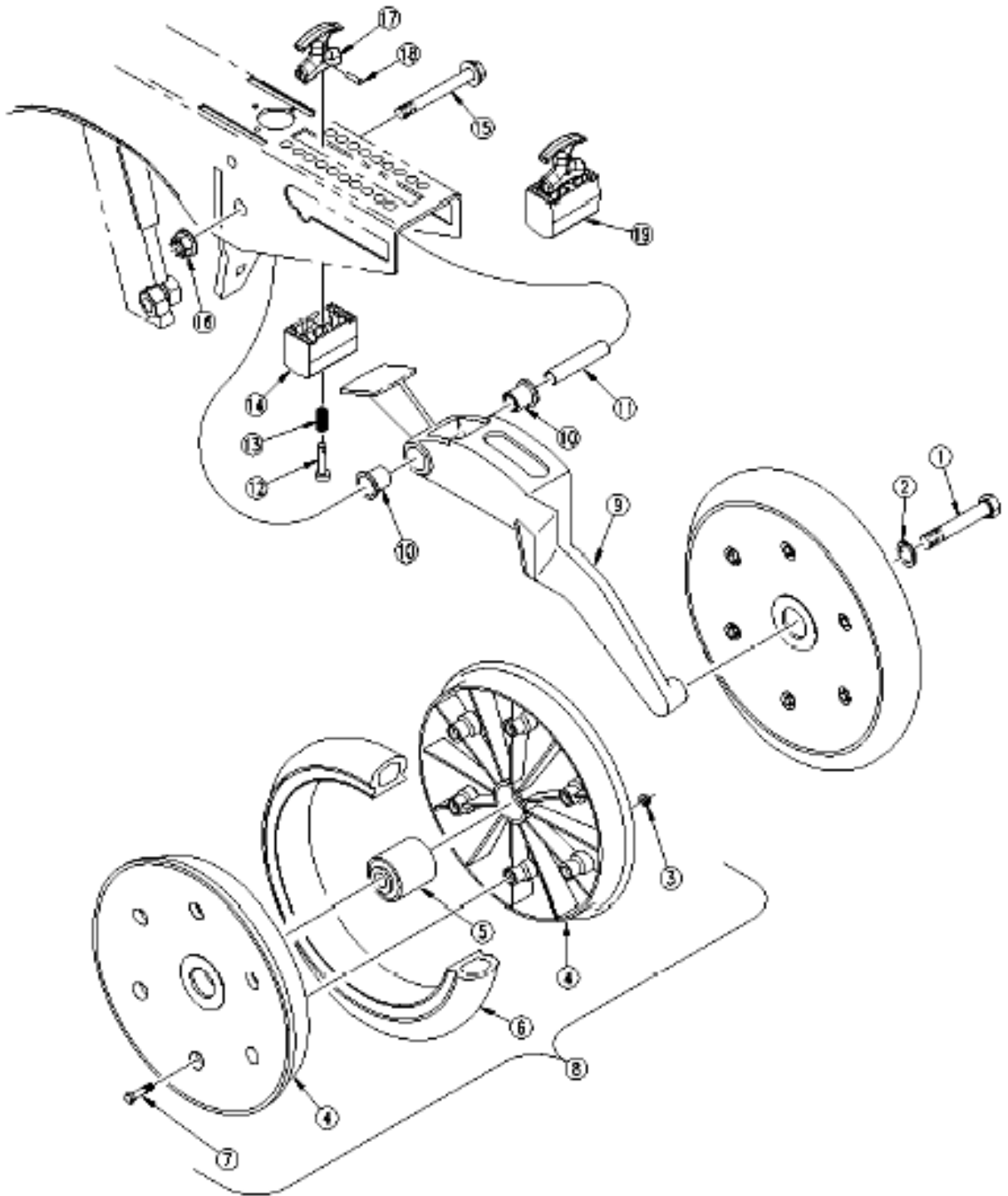

NO-TILL VINEYARD DRILL PARTS

<u>Ref. No.</u>	<u>Part No.</u>	<u>DESCRIPTION</u>
1.	NYNUT-12NC	Hex Nut 3 /4" -10 PLT Nylock
2.	812-031C	Casting Coulter Spring Washer
3.	204-107D	Spring Rod Sleeve 1-1/8" OD
4.	807-074C	Spring 2.25" OD x 0.5" Coil
5.	817-029C	Bushing Coulter Casting
6.	149-963S	Coulter Mount. Casting Assembly
7.	800-001C	Grease Zerk Straight 1 /4" -28
8.	204-026D	Shank 1-1/2" D x 22 Fert. Coult.
10.	805-043C	Pin Spiral 3/8" x 2-1 /2" Plain
11.	204-075H	Coulter Spring Rod Weldment
12.	801-040C	Screw Sq. Head 5/8" -11 x 1" Cup PT
13.	149-162H	Coulter Stop Weldment
14.	804-039C	Flat Washer 1-1 /4" SAE Plt.
15.	GPN-04X40C	1/4" Cotter Pin Plt.
16.	803-181C	Nut Hex Flange Lock 3/4" -10 Plt
17.	817-051C	Swing Arm Bushing
18.	149-181E	Coulter Swing Arm Weldment
19.	816-009C	Oil Seal Double Lip
20.	822-021C	Bearing Cone LM-67048
21.	822-020C	Bearing Cup LM-67010
22.	CBNC508024	1/2 " X 1-1/2" NC Carriage Bolt
23.	200-039V	Coulter Hub and Cup Assembly
24.	804-055C	Washer, Spindle 7/8"
25.	820-116C	Coulter Blade
26.	804-015C	Spring Lock Washer 1/2"
27.	HXNUT-08NC	1/2" Hex Nut, NC
28.	200-001D	Hub Grease Cap
29.	805-017C1	Cotter Pin 3/16" X 1-3/4"
30.	803-029C	Nut, Hex Slotted 7/8"-14 Plt.
31.	200-002S	Coulter Hub Package

NO-TILL VINEYARD DRILL PARTS BREAKDOWN

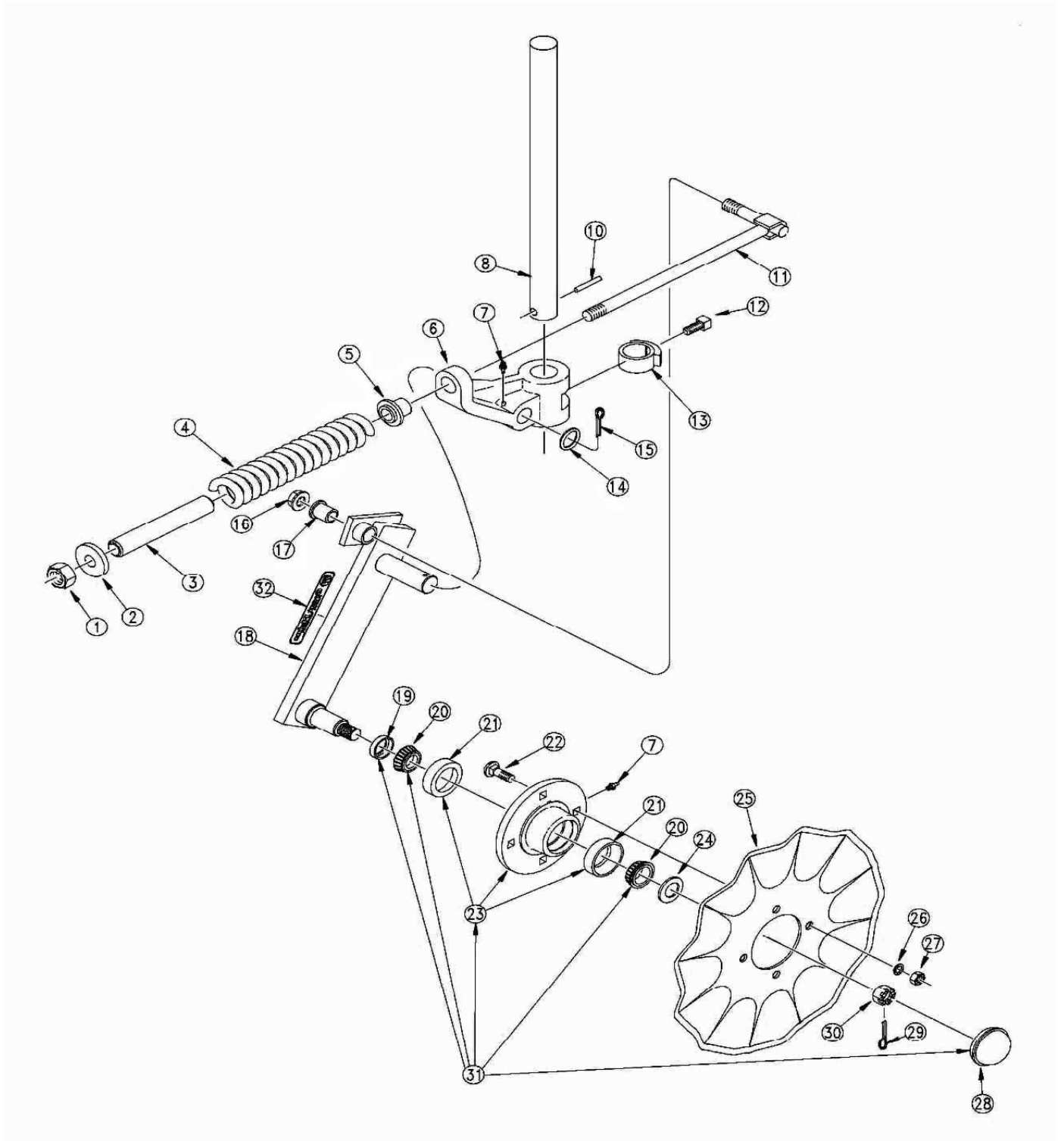

NO-TILL VINEYARD DRILL CLAMP KIT

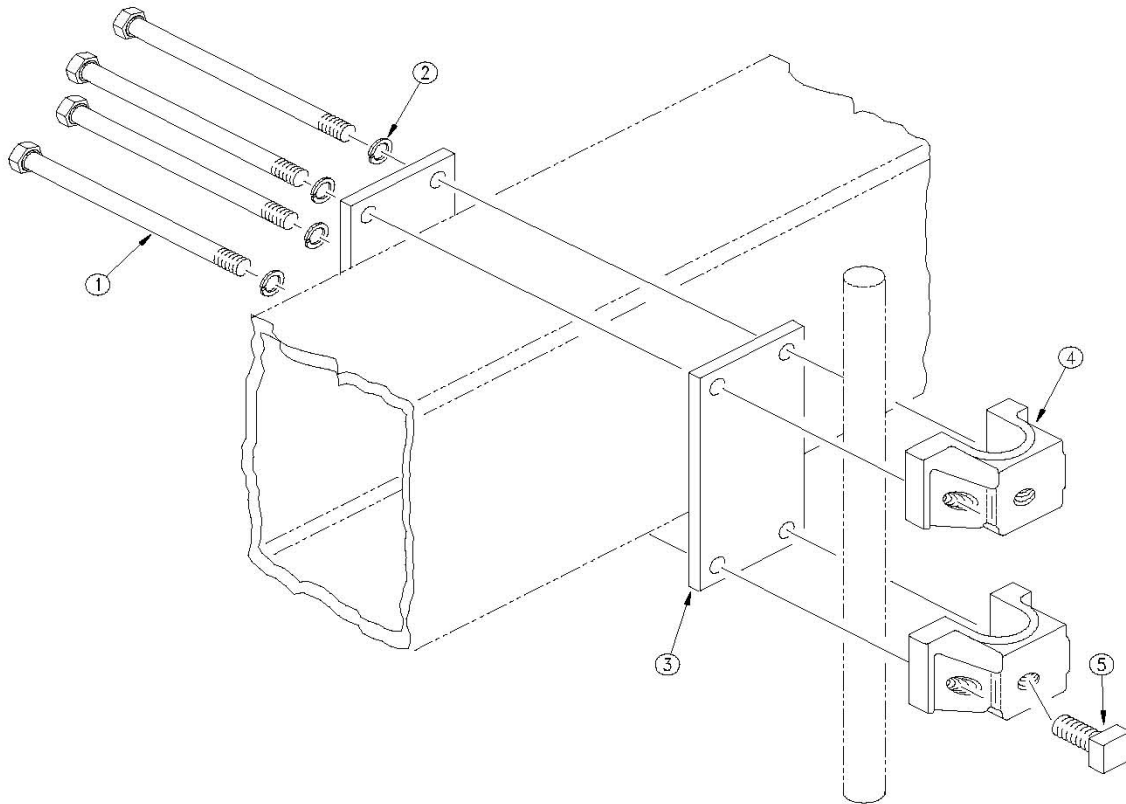

<u>Ref.No.</u>	<u>Part No.</u>	<u>DESCRIPTION</u>
1.	CSNC508080	1/2" X 5" NC Cap Screw Plt.
2.	LWASHER-08	1/2" Lock Washer Plt.
3.	204-083D	Clamp Plate 3" Sq. Bar
4.	204-072D	Clamp Shank 1-1/2" Dia.
5.	801-040C	Square Head Screw 5/8" x 1" Cup Plt.
6.	204-064K	Clamp Kit - includes items: 1, 2, 3, 4, and 5

NO-TILL DRILL SPROCKET AND CHAIN ASSEMBLIES

DRIVE CHAIN

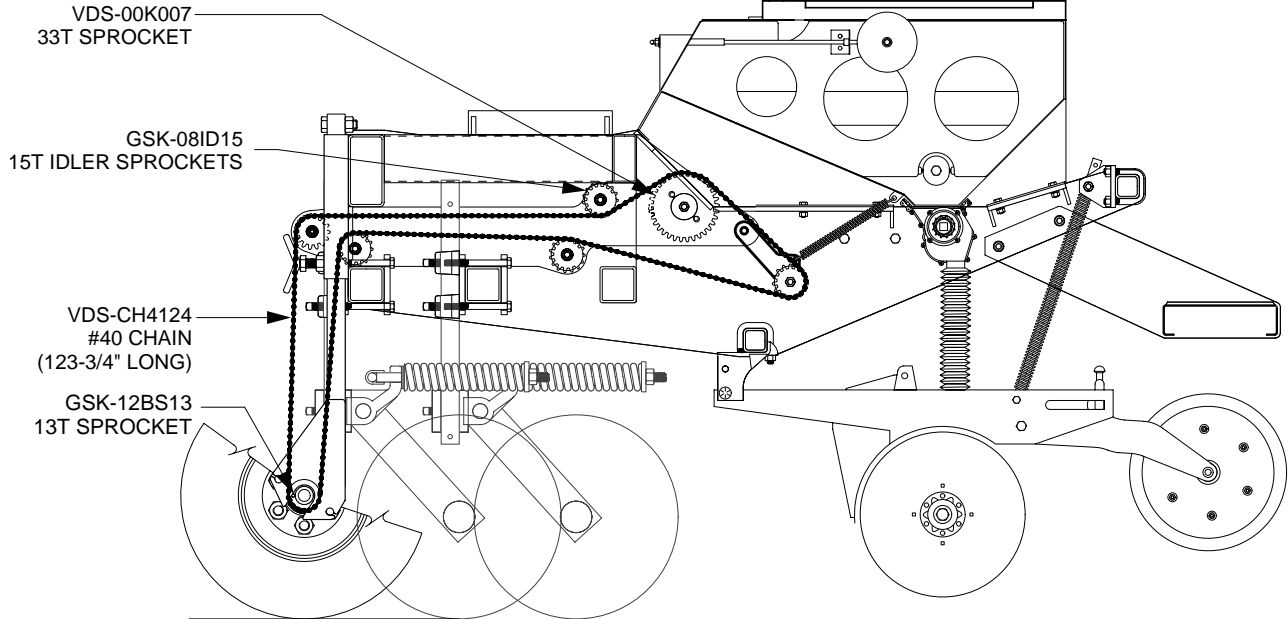

END CHAIN

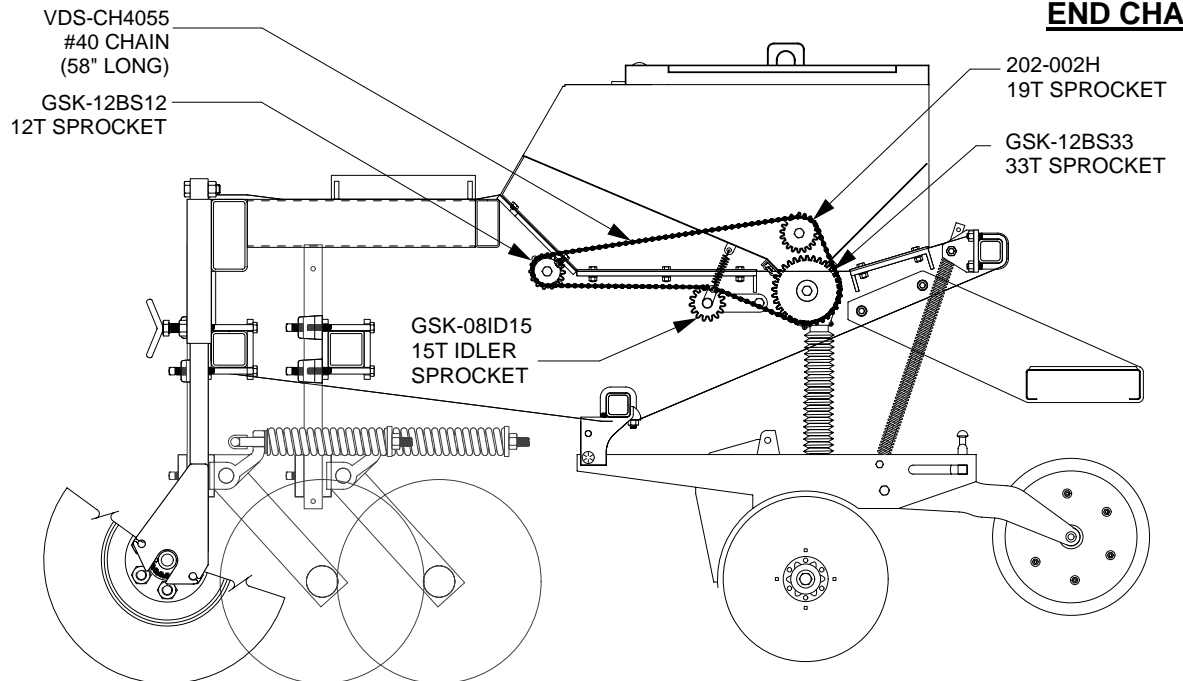

T.G. SCHMEISER CO., INC.®

Limited Warranty Statement

T. G. Schmeiser Co., Inc. warrants each new Schmeiser® product to be free from defects in material and workmanship. This warranty is applicable only for the normal service life expectancy of the product or components, not to exceed twelve (12) consecutive months from the date of delivery of the new Schmeiser product to the original purchaser.

Genuine T. G. Schmeiser Co., Inc. replacement parts and components will be warranted for 90 days from date of purchase, or the remainder of the original equipment warranty period, whichever is longer.

Under no circumstances will it cover any merchandise or components thereof, which, in the opinion of the company, has been subjected to misuse, unauthorized modifications, alteration, an accident or if repairs have been made with parts other than those obtainable through T. G. Schmeiser Co., Inc.

The Company in no way warrants engines, batteries, cylinders, tires or other trade accessories since these items are warranted separately by their respective manufacturer. Expendable components such as points, shanks, blades, rings, bearings, teeth, and the like are excluded from this warranty.

Our obligation under this warranty shall be limited to repairing or replacing, free of charge to the original purchaser, any part that, in our judgment, shall show evidence of such defect, provided further that such part shall be returned within thirty (30) days from date of failure to T. G. Schmeiser Co., Inc., routed through the dealer and distributor from whom the purchase was made, transportation charges prepaid.

This warranty shall not be interpreted to render T. G. Schmeiser Co., Inc. liable for injury or damages of any kind or nature to person or property. This warranty does not extend to the loss of crops, loss because of delay in harvesting, or any expense or loss incurred for labor, substitute machinery, rental or for any other reason.

Except as set forth above, T. G. Schmeiser Co., Inc. shall have no obligation or liability of any kind on account of any of its equipment and shall not be liable for special or consequential damages. T. G. Schmeiser Co., Inc. makes no other warranty, expressed or implied, and, specifically, T. G. Schmeiser Co., Inc. disclaims any implied warranty or merchantability or fitness for a particular purpose. Some states or provinces do not permit limitations or exclusions of implied warranties or incidental or consequential damages, so the limitations or exclusion in this warranty may not apply.

This warranty is subject to any existing conditions of supply, which may directly affect our ability to obtain materials or manufacture replacement parts.

T. G. Schmeiser Co., Inc. reserves the right to make improvements in design or changes in specifications at any time, without incurring any obligation to owners of units previously sold.

No one is authorized to alter, modify or enlarge this warranty nor the exclusion, limitations and reservations.

**WARRANTY VOID IF NOT REGISTERED
WITHIN 30 DAYS OF PURCHASE DATE**

Schmeiser Vineyard Drill
Maintenance & Repair Record

Date of Service	Service or Repair Performed	Parts Replaced

Notes

A large rectangular box with a black border, containing 18 horizontal gray bars for writing notes. The bars are arranged in a repeating pattern of a white bar followed by a gray bar, starting with a white bar at the top and ending with a gray bar at the bottom.